

AC solenoids

2

Product group

W BA

Function

- Increasing force vs. stroke characteristic for type W BA X 006 up to 010 almost linear force vs. stroke characteristic for type W BA X 030 up to 070
- Push and pull type

Construction

- Armature in wear-resistant armature guidances
- Insulation materials of the exciter coil correspond to thermal class F
- Electrical connection version A 01 bipolar clamp
- Schutzart nach DIN VDE / EN 60529 IP 00
- Only for installation protected against contact
- Fastening with universal frame or dedendum angle
- The noise caused by physical conditions of AC solenoids may be perceived as annoying in quiet rooms and especially when mounted on resonant bases

Application examples

- Tooling machines, office machines, packing machines, textile machines
- Measuring and control technology

Options and accessories

- Please contact us for application related solutions

Standards

- Design and testing according to VDE 0580
- Production according to ISO 9001



Fig. 1: Type W BA X 030 A 00 A01

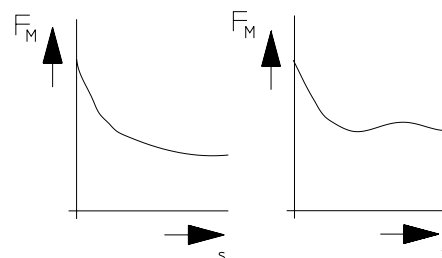

Fig. 3: force vs. stroke characteristic

Technical data

W BA X	006								010										
Operating mode	S1 100%	S3 40%	S3 25%	S3 15%	S1 100%	S3 40%	S3 25%	S3 15%	S1 100%	S3 40%	S3 25%	S3 15%	S1 100%	S3 40%	S3 25%	S3 15%			
Magnetic force F_M	N -	N -	N -	N -	N -	N -	N -	N -	N -	N -	N -	N -	N -	N -	N -	N -			
Apparent power	- VA	- VA	- VA	- VA	- VA	- VA	- VA	- VA	- kVA	- kVA	- kVA	- kVA	- kVA	- kVA	- kVA	- kVA			
Stroke s (mm)	0	12 26	20 55	22 72	23 104	17 0,04	34 0,08	37 0,11	41 0,15	3	6,9 57	9,0 86	10 103	12 135	15,6 0,10	20 0,15	24 0,18	28 0,23	
		5	5,3 68	7,1 98	8,1 116	9,9 145	11,6 0,12	12 0,17	14 0,21	17 0,26	8	4,4 78	6,3 110	7,1 130	8,7 160	9,7 0,15	11 0,20	13 0,24	15 0,29
		10	4,1 85	5,8 118	6,7 136	8,0 166	9,7 0,17	11 0,22	13 0,27	15 0,32	15	3,4 100	5,8 136	6,7 157	8,1 179	7,9 0,20	11 0,27	13 0,32	15 0,37
		20	2,4 110	4,4 150	5,6 171	6,9 210	5,8 0,23	10,2 0,30	12 0,34	14 0,40	Rated work A_N (Ncm)	4,8	8,8	11,2	13,8	11,6	20,4	24	28
Actuation time t_1 (ms)	89								98										
Fall time t_2 (ms)	85								97										
Armature weight m_A (kg)	0,047								0,065										
Solenoid weight m_M (kg)	0,227								0,315										
W BA X	030								050										
Operating mode	S1 100%	S3 40%	S3 25%	S3 15%	S1 100%	S3 40%	S3 25%	S3 15%	S1 100%	S3 40%	S3 25%	S3 15%	S1 100%	S3 40%	S3 25%	S3 15%			
Magnetic force F_M	N -	N -	N -	N -	N -	N -	N -	N -	N -	N -	N -	N -	N -	N -	N -	N -			
Apparent power	- kVA	- kVA	- kVA	- kVA	- kVA	- kVA	- kVA	- kVA	- kVA	- kVA	- kVA	- kVA	- kVA	- kVA	- kVA	- kVA			
Stroke s (mm)	0	74 0,06	95 0,12	103 0,18	109 0,24	108 0,08	130 0,17	140 0,25	147 0,37	3	24 0,13	41 0,25	51 0,34	60 0,42	29 0,17	54 0,33	66 0,46	77 0,63	
		5	19 0,18	32 0,32	40 0,44	46 0,51	23 0,20	43 0,40	52 0,54	61 0,75	8	17 0,23	29 0,41	36 0,53	41 0,63	19 0,26	36 0,51	44 0,70	52 0,92
		10	17 0,26	28 0,46	35 0,58	40 0,70	19 0,31	35 0,60	43 0,80	50 1,04	15	18 0,34	29 0,58	36 0,73	41 0,85	21 0,40	37 0,79	45 1,03	53 1,32
		20	18 0,45	30 0,70	37 0,86	43 0,99	22 0,54	40 1,01	48 1,29	56 1,60	25	19 0,50	31 0,81	38 0,97	43 1,11	22 0,66	42 1,18	52 1,49	59 1,84
		30	16 0,57	28 0,93	34 1,11	40 1,26	25 0,80	46 1,38	55 1,71	64 2,10	35					24 0,90	43 1,57	52 1,94	60 2,35
		40					20 1,03	36 1,78	44 2,18	56 2,61	Rated work A_N (Ncm)	48	84	102	120	80	144	176	224
Actuation time t_1 (ms)	112								117										
Fall time t_2 (ms)	115								124										
Armature weight m_A (kg)	0,15								0,19										
Solenoid weight m_M (kg)	0,65								1,10										

For type W BA X 006 series "B" (Push type, Fig. 4) and only for S1 the magnetic force is reduced about approx. 30%.

W B A X	070							
	S1 100%		S3 40%		S3 25%		S3 15%	
Operating mode	N -		N -		N -		N -	
Magnetic force F_M	N -		N -		N -		N -	
Apparent power	- kVA		- kVA		- kVA		- kVA	
Stroke s (mm)	0	84 0,12	112 0,30	123 0,46	129 0,62			
	3	46 0,27	73 0,52	91 0,73	102 0,91			
	5	34 0,33	56 0,61	70 0,85	79 1,04			
	8	29 0,40	48 0,77	60 1,06	69 1,27			
	10	28 0,46	47 0,88	59 1,20	66 1,42			
	15	28 0,59	47 1,10	59 1,49	66 1,73			
	20	30 0,76	50 1,39	62 1,80	69 2,10			
	25	32 0,91	53 1,64	65 2,12	74 2,42			
	30	34 1,12	56 1,95	69 2,45	77 2,79			
	35	37 1,31	60 2,22	72 2,79	81 3,13			
	40	41 1,52	65 2,51	77 3,10	86 3,48			
	45	41 1,79	65 2,84	77 3,47	86 3,88			
Rated work A_N (Ncm)		184	292	347	387			
Actuation time t_1 (ms)		126						
Fall time t_2 (ms)		143						
Armature weight m_A (kg)		0,26						
Solenoid weight m_M (kg)		1,70						

Notes on the tables

The magnetic force values indicated in the table refer to 90 % of the rated voltage ($U_N = 230V/50$ Hz, deviations of the magnetic force may occur for other voltages) and the normal operating temperature. Due to natural dispersion the magnetic force values may deviate by approx. ± 10 % from the table values.

The normal operating temperature is based on:

- a) Mounting on heat-insulating base
- a) Rated voltage 230 V, 50 Hz
- b) Operating mode S1 (100 %) - S3 (15%)
- c) Reference temperature 35°C
- c) Operating frequency 120 1/h (higher operating frequency on request)

At the operation of the devices DIN 31000 / VDE 1000 und DIN VDE 100 part 420 must be respected.

Rated voltage

Rated voltage 230 V/50 Hz, the exciter coil can be adjusted to other rated voltages on request.

Information and remarks concerning European directives can be taken from the correspondent information sheet which is available under *Produktinfo.Magnet-Schultz.com*.

Note on the RoHS Directive

The devices presented in this document do not fall into the scope of RoHS Directive and to our knowledge they do not become part of products which fall into this scope. In case of surfaces zinc coating with yellow chromating and zinc iron with black chromating separate agreements are necessary for applications within the scope of RoHS.

Please make sure that the described devices are suitable for your application. Supplementary information concerning its proper installation can be taken also from the  -Technical Explanation, the effective DIN VDE0580 as well as the relevant specifications.

This part list is a document for technically qualified personnel.

The present publication is for informational purposes only and shall not be construed as mandatory illustration of the products unless otherwise confirmed expressively.

Dimension tables of the series W BA

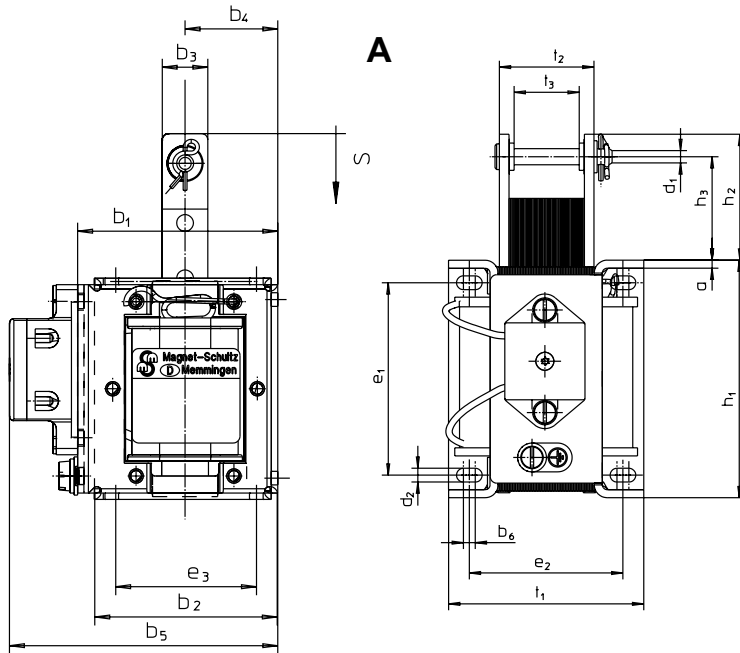

Fig. 3:
Type W BA X 006 A00 A01 to
W BA X 050 A00 A01
(Pull type)

Type	W BA X Arrangement A and B			
Size	006	010	030	050
Dimension	Dimensions in mm			
a	1,5	1,5	2	2,5
b ₁	47	47	57	67
b ₂	43	43	51,5	61
b ₃	10,8	10,8	14,8	13,6
b ₄	21,75	21,75	26,5	31,5
b ₅	63	63	77	87
b ₆	2,8	2,8	2,7	3,7
d ₁	4	4	5	5
d ₂	3,2	3,2	3,2	4,3
d ₃	M4	M4	M5	M5
e ₁	42	42	48	60
e ₂	24	32,5	42	48
e ₃	34	34	40	45
h ₁	52	52	65	74
h ₂	34	34	46,5	58
h ₃	27	27	38,5	51
l ₁	15	15	15	15
l ₂	20	20	17	17
s	20	20	30	40
t ₁	32	40,5	53	61
t ₂	12,6	21	23,5	29,5
t ₃	6,6	15	14,3	20,3

Table 1 referring to fig. 3 up to 6

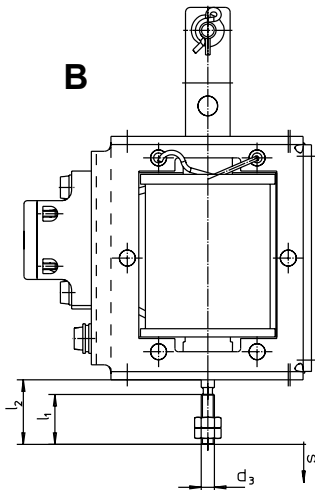

Fig. 4:
Type W BA X 006 B00 A01 to
W BA X 050 B00 A01
(Push type,
dimensions see fig. 3)

Dimension table of the series W BA

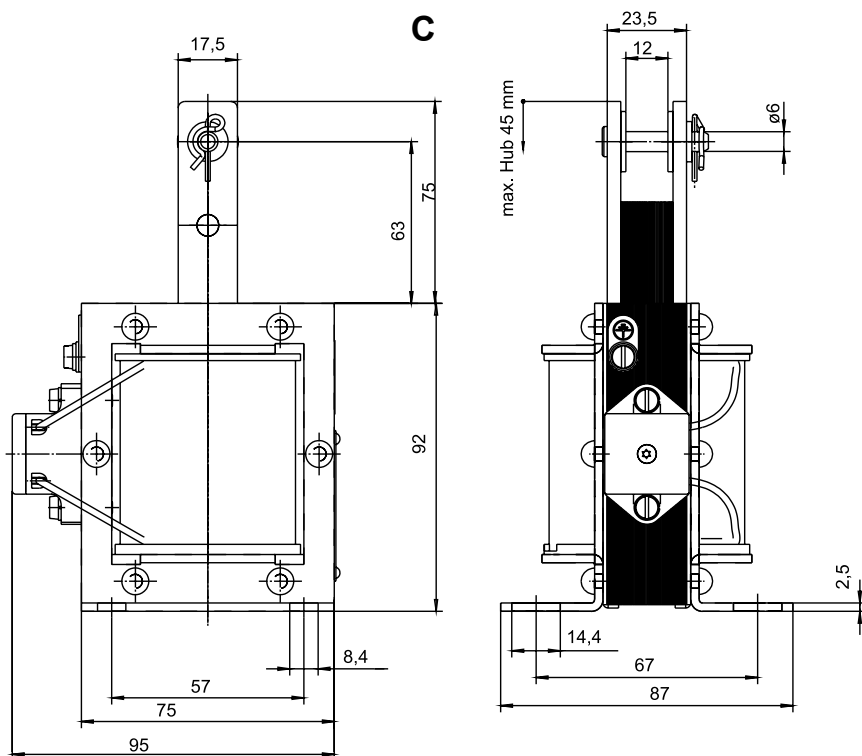

Fig. 5:
Type W BA X 070 C00 A01 to W BA X 070 C00 A01
(pull type)

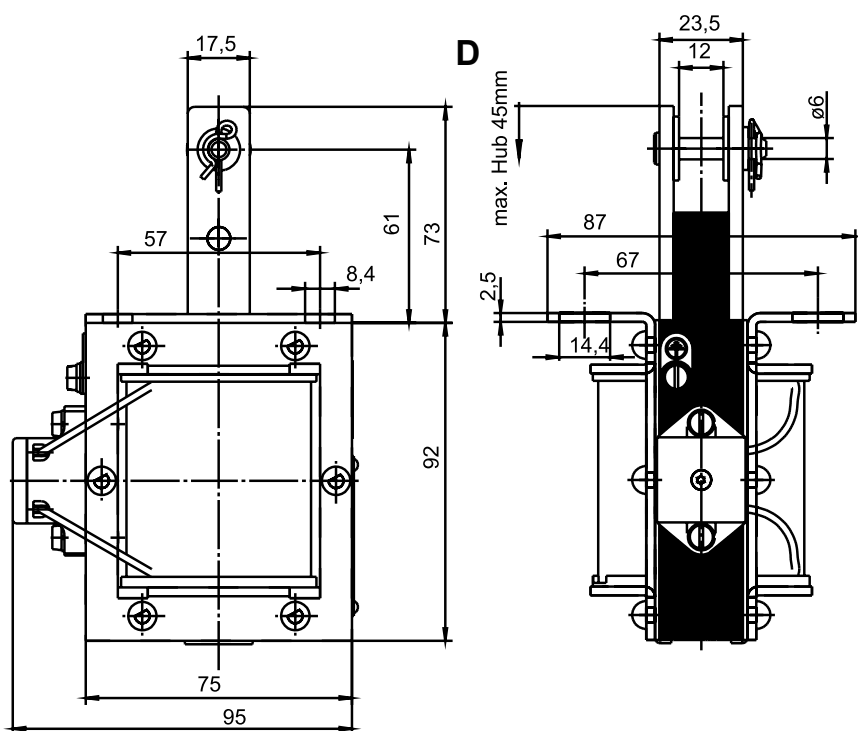

Fig. 6:
Type W BA X 070 D00 A01
(Pull type)

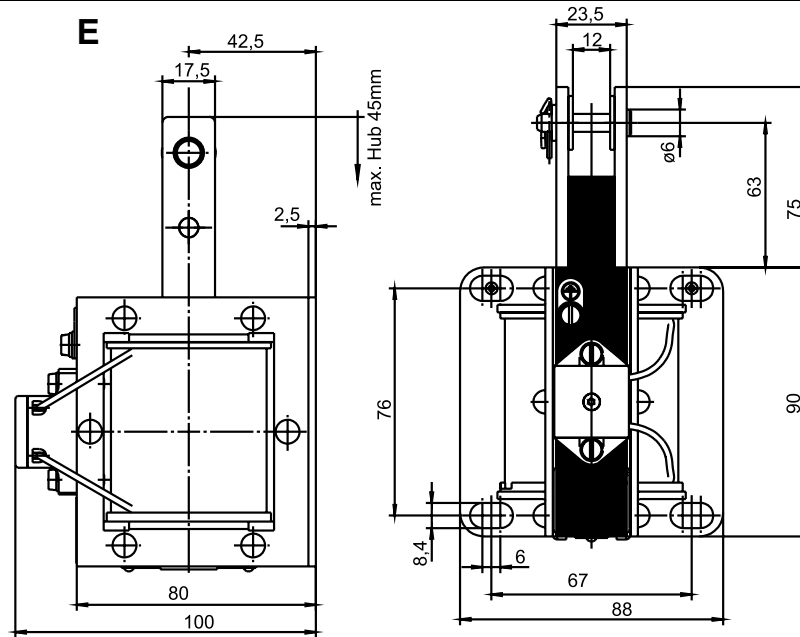
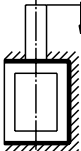
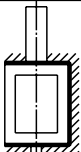
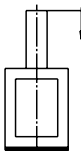
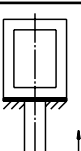
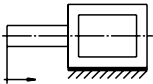

Fig. 7:
Type W BA X 070 E00 A01
(Pull type)

Key for type designation

Type	Construction size and version	Designation
W BA X	006 A00 A01 010 A00 A01 030 A00 A01 050 A00 A01	Pull type Universal fastening A 
	006 B00 A01 010 B00 A01 030 B00 A01 050 B00 A01	Push type Universal fastening B 
	070 C00 A01	Pull type C 
	070 D00 A01	Pull type D 
	070 E00 A01	Pull type E 

Specials designs

Please do not hesitate to ask us for application-oriented problem solutions. In order to find rapidly a reliable solution we need complete details about your application conditions. The details should be specified as precisely as possible in accordance with the relevant -Technical Explanations.

If necessary, please request the support of our corresponding technical office.

Order example

Type W BA X 070 C 00 A01
Voltage 230 V, 50 Hz
Operating mode S1 (100 %)