

Electric Mini Bolt

Type EMB

Benefit from more than 100 years of experience. Use our unmatched end-to-end service: from off-the-shelf products to tailor-made designs - prototyped, tested and manufactured to your exact requirements.

Get free advice, a detailed quote or buy now

Email us at sales@magnetschultz.co.uk or call +44(0)1483 794700

Applications

secure locking of hinged and sliding elements in -

cabinets • access hatches • lockers •
grills • mechanisms • vents

Function

- energise-to-lock (EL) or spring-to-lock (SL) versions
- solenoid operated
- 15mm bolt stroke
- manual over-ride

Standard features

- stainless steel bolt with 2 position switches
- encapsulated solenoid coil, insulation class F
- flying lead connections
- installation in any attitude
- robust construction
- maintenance-free bearings, long life
- corrosion resistant materials
- 12 or 24 Vdc

Options on request

- stainless steel mounting plate with or without Door Proving Switch
- keeper plates (allowing slam-lock operation)
- side mounting plate
- boxed version
- alternative bolt length and design

Standards

- solenoid designed and tested to VDE 0580
- ISO 9001:2008



Fig. 1 EMB-SL
(spring to lock, with mounting plate)



Fig. 2 EMB-SL-B
(boxed with mounting plate & keeper)

ELECTRIC MINI BOLT (EMB)		
Operating mode - Solenoid * Duty rating ED		S1 100% (ie continuous)
		Solenoid force F_M (N)
		Spring return force (N)
	0	7.25
	15	2.6
Power Consumption P20	(W)	7
Weight (without optional parts)	(kg)	0.5
Radial bolt load, max allowable	(N)	1000**

* Solenoid GFCX 030 X00 E13 to data sheet 'GFCX 030 X00 E13'

** The bolt will not withdraw if a side-load is present

Table Basis

Terms used are defined in Technical Definition GXX available at www.magnetschultz.co.uk

Force figures F_M are gross. For net values deduct spring force

Magnetic forces F_M are based on

- 24v 100% duty coil
- 35°C ambient temperature
- coil in the Hot condition
- armature in horizontal attitude
- 90% of the rated voltage
- heat-insulated mounting

Solenoid coil is 100% rated at specified voltage

Values given may vary by up to 10% owing to inherent and manufacturing tolerances

Supply Voltage

Standard voltages: 12V and 24VDC , others on request

Versions

Other standard shotbolt types are available, including IP54, IP65 and ATEX – see respective data sheets

Also, special and modified versions, including

- enclosures and finishes
- long strokes

Contact our Sales department for assistance

Safety

The customer is responsible for ensuring that devices are suitable for their application and that, even if one should fail, safety in use is not compromised. We supply Technical Definition documents to help users understand our products and assistance is available from our specialists

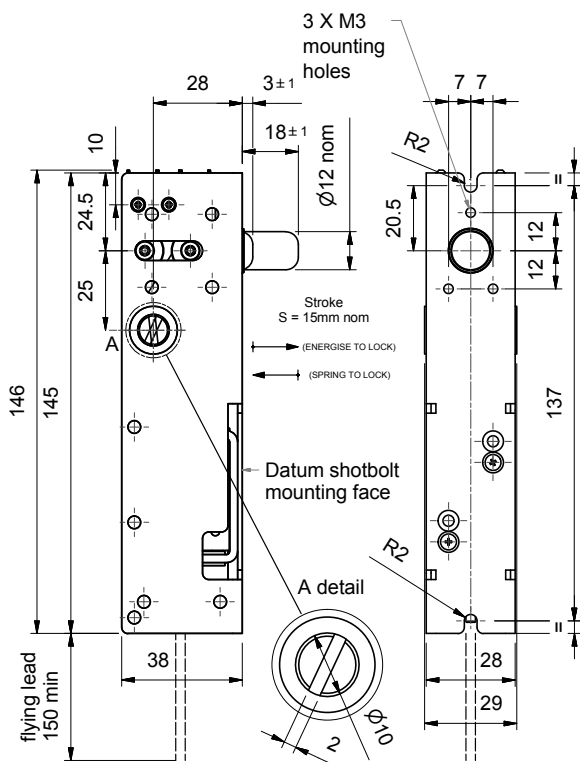

Fig.3 Spring-to-lock (SL) and Energise-to-lock (EL) versions

Switches

Both EMB-EL and EMB-SL incorporate two SPDT (single-pole/double-throw) snap-action switches, to signal each extent of bolt travel.

Contact rating - 5 Amps @ 125/250 VAC (not rated for DC)

The switches are fixed and operate at 4 ± 1 and 17 ± 1 mm from the datum.

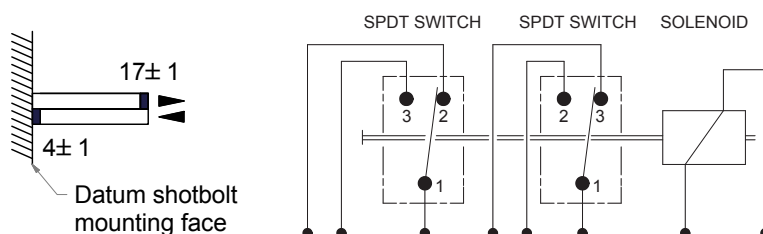

Fig.4 Bolt position switches

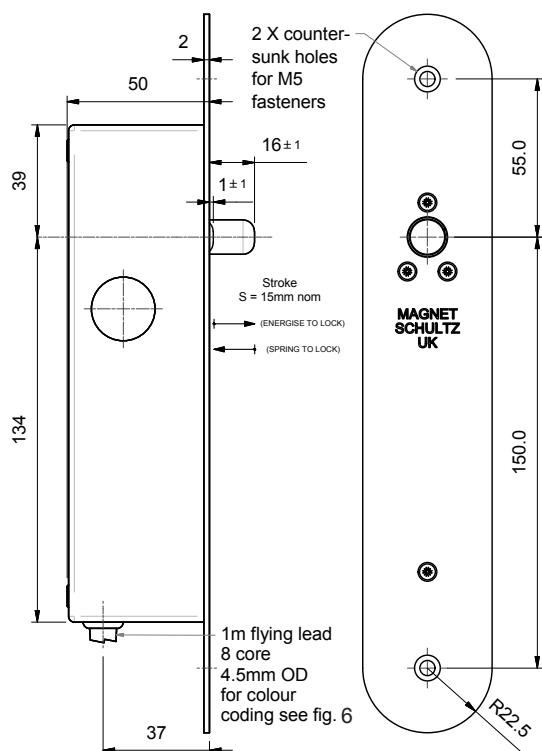

Fig. 5 boxed version
EMB-SL-B, EMB-EL-B

Core	Allocation
White	Solenoid
Black	Solenoid
Brown	Bolt in-common
Red	Bolt in-closed
Orange	Bolt in-open
Yellow	Bolt out-common
Green	Bolt out-closed
Blue	Bolt out-open

Fig. 6 Multi-core cable
(applies to boxed versions only)

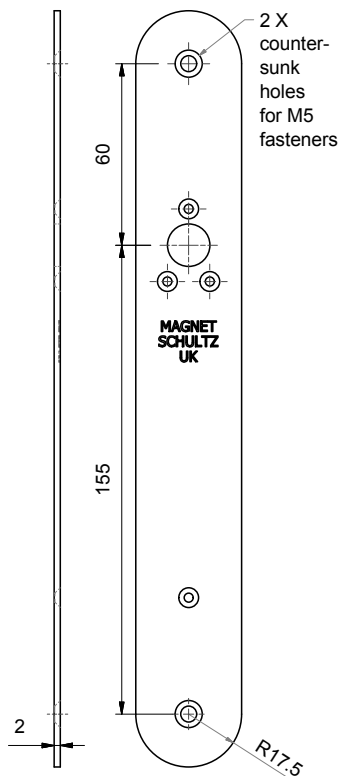

Fig. 7 Plain mounting plate

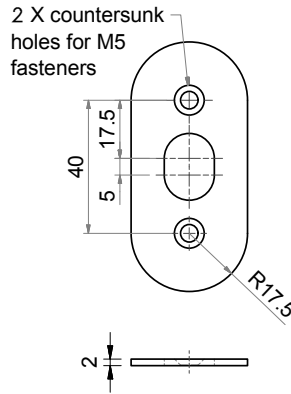

Fig. 8 plain keeper

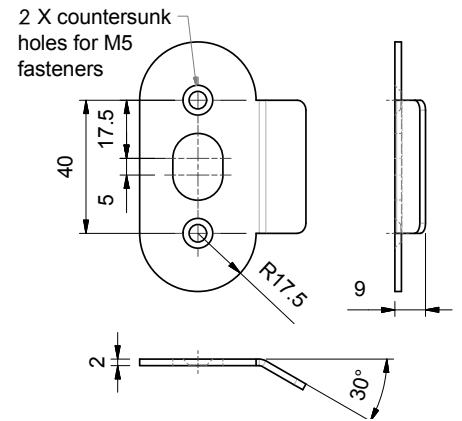

Fig. 9 slam-lock keeper

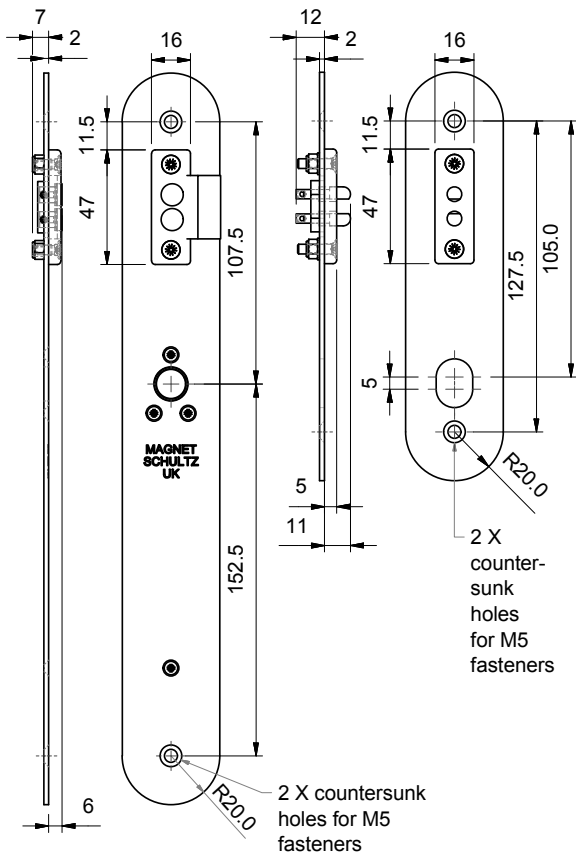

Fig. 10 DPS mounting plate and keeper

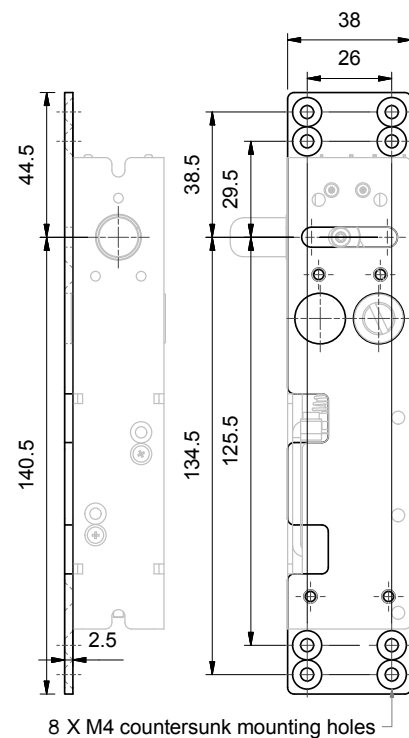

Fig. 11 Side mounting plate

Order codes

Order example for shotbolt: spring-to-lock/boxed/12V 100% coil

Order Example	EMB	SL	B	12v 100%
Type	EMB			
Function		SL (spring-to-lock) EL (energise-to-lock)		
Box (if required)			B	
Voltage / % duty rating				12V / 100% 24V / 100%

Ancillary Items	Order code
Plain mounting plate & keeper set - fig.7&8	A9900059
DPS mounting plate & keeper set - fig.10	A9900060
Side mounting plate - fig.11	P0101358
Slam-lock keeper - fig.9	P0101360
Door proving switch - fig.12	P0200342

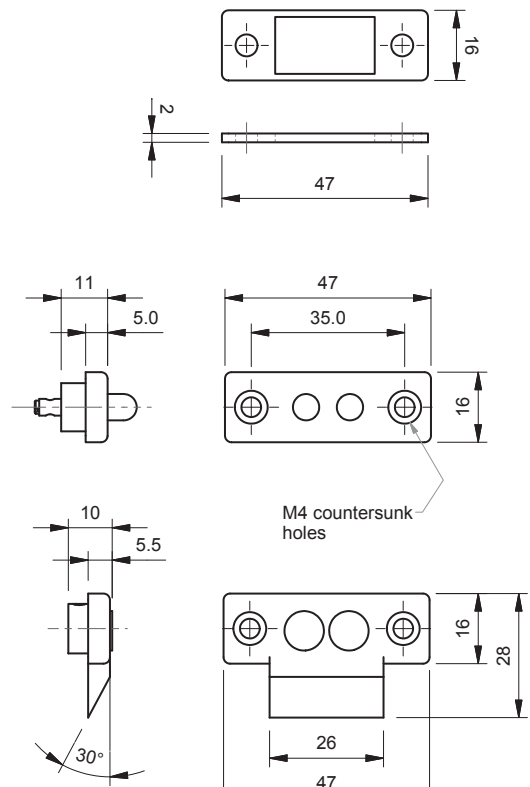
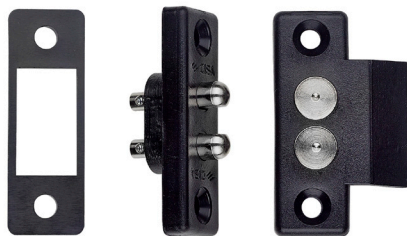

Fig.12 Door proving switch

Need more information or advice?

Email one of our technical experts at sales@magnetschultz.co.uk or call +44(0)1483 794700 now