

## Proportional Solenoids to RL 94/9/EG (ATEX 95)

# 4

Product Group

# G R C E

Pamphlet

- To DIN VDE 0580 and RL 94/9/EG (ATEX 95)
- Pressure-tight armature space, rated operating pressure 250 bar
- Magnetic force/stroke characteristic horizontal within proportional control range
- To a large extent proportional behaviour between force and current
- Small hysteresis through precise armature bearing
- Quick floating times
- Pushing type
- Mounting via central thread
- Simple exchange of the coil without opening the hydraulic circuit
- Coil winding to insulation classification H
- Electrical connection and protection class if mounted properly:
  - Connection cable Li12Y11Y 3 x 1,5
  - Protection class to DIN VDE 0470/EN 60 529 - IP67
  - Explosion protection  II 2G EEx m II T4
  - Supplementation of permission for dust guard, 2D, is being prepared.
- Manual override
- Modifications and special designs on request
- Application examples:  
Particularly used as proportional actuator in hydraulic control systems and control circuits



Fig. 1: G R C E 037 AMX A01



## Technical Data

<b>G R C E 037 AMX A01</b>	
Operating mode	S1 (100 %)
Rated Voltage $U_N$	24 V
Rated Resistance $R_{20}$	23.1 $\Omega$
Rated Current $I_N$	0.6 A
Control Current Range	0 to 0.66 A
Maximum Power $P_G$	15.6 W
Ambient temperature $T_a$	- 20° to + 50° C

Mounting on hydraulic valve with multiple mounting in single operation:

minimum size: 46 x 46 x 66 mm<sup>3</sup> on  
base plate 46 x 66 x 30 mm<sup>3</sup>

material: iron or material with equal, or better heat respectively.

Be appropriate measures it is to be ensured that the given maximum values, especialz the control current level, are not exceeded.

On request the coil winding can be adjusted to other current and resistance values .

Owing to natural dispersion the magnetic-force values may deviate by  $\pm 5\%$  from the listed values.

On request, the armature space can be de-aerated and the push-rod can be adjusted.

Mech. modifications of the flange are possible on request.

The Solenoid interior and armature bearing are resistant to all neutral fluids that are commonly used in hydraulics.

Please contact us if you intend to use other operating media.

**Please notice the relevant operating manuals which are delivered with each device. A declaration of the manufacturer is enclosed once.**

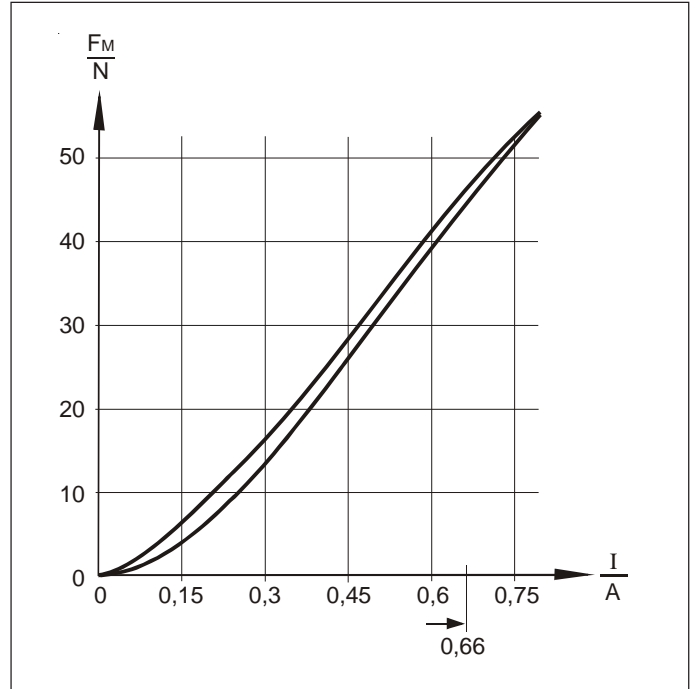

**Fig. 2:** magnetic force / current characteristic G R C E 037 AMX A01 at  $s = 1$  mm

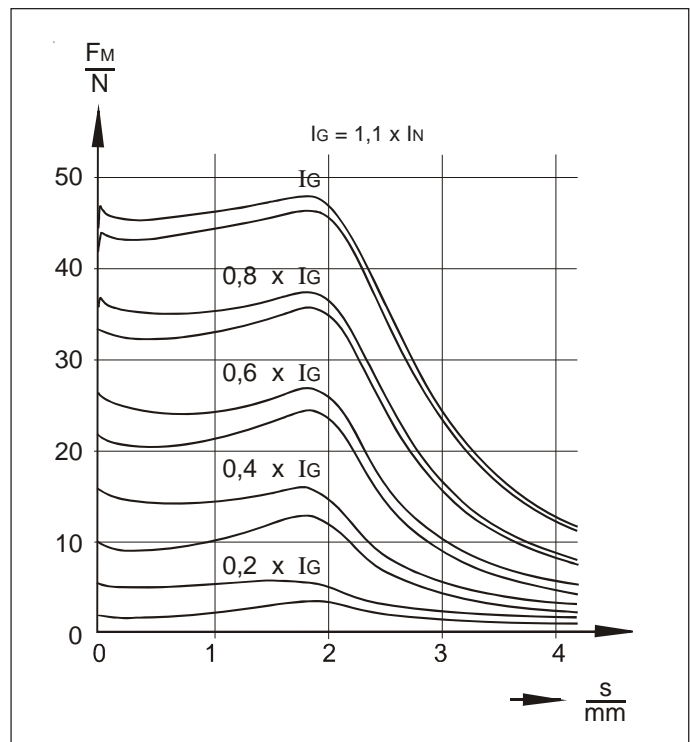

**Fig. 3:** magnetic force / stroke characteristic G R C E 037 AMX A01

## Magnetic Body

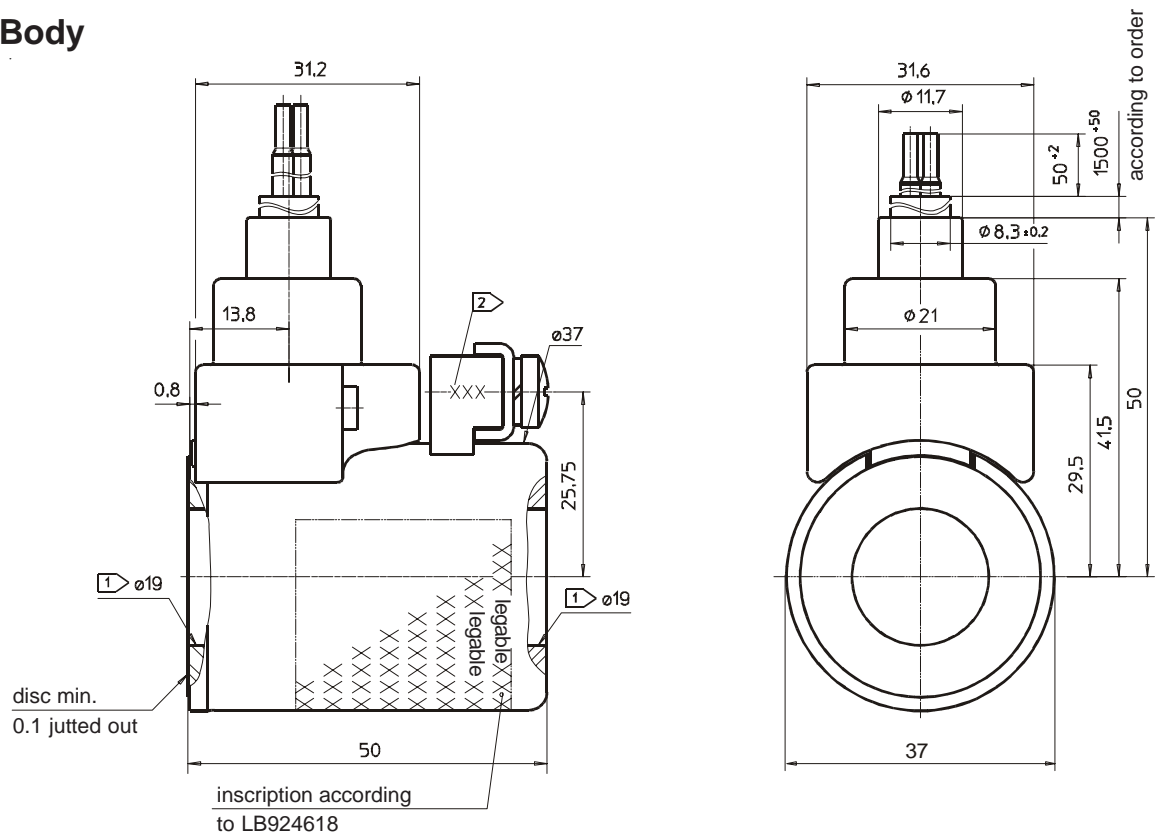

Fig. 4: Coil 924618 (FHMPE037924618)

## Tube

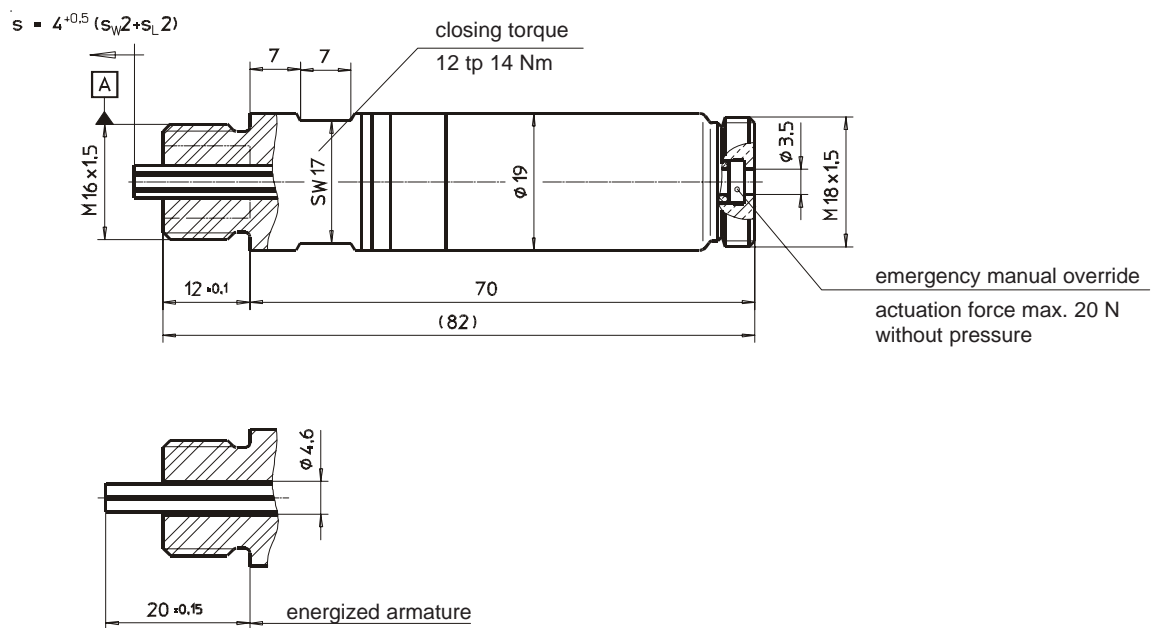
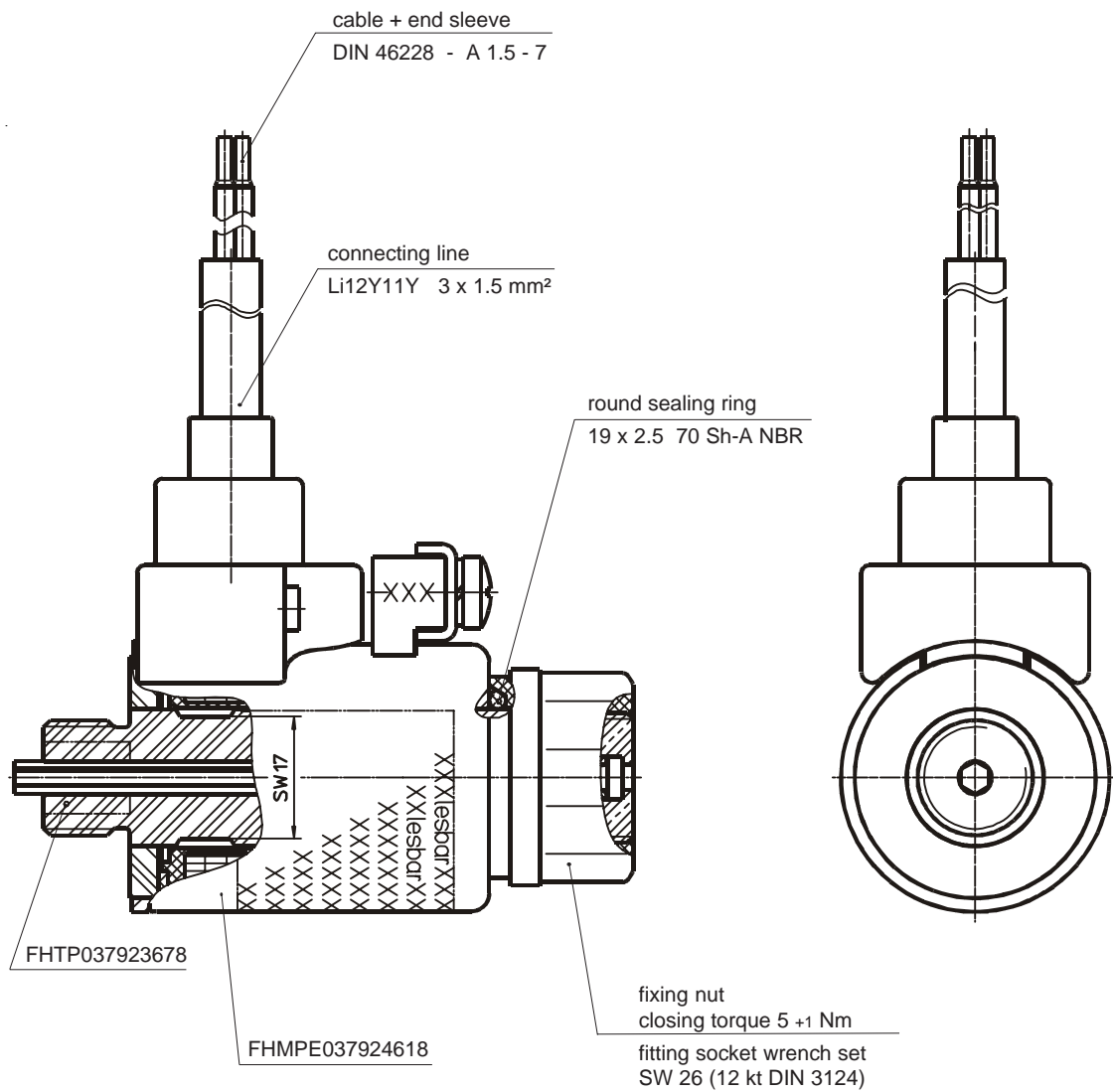

Fig. 5: Tube 923678 (FHTP037923678)

## Proportional Solenoid, complete



### Wiring diagram

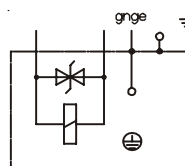
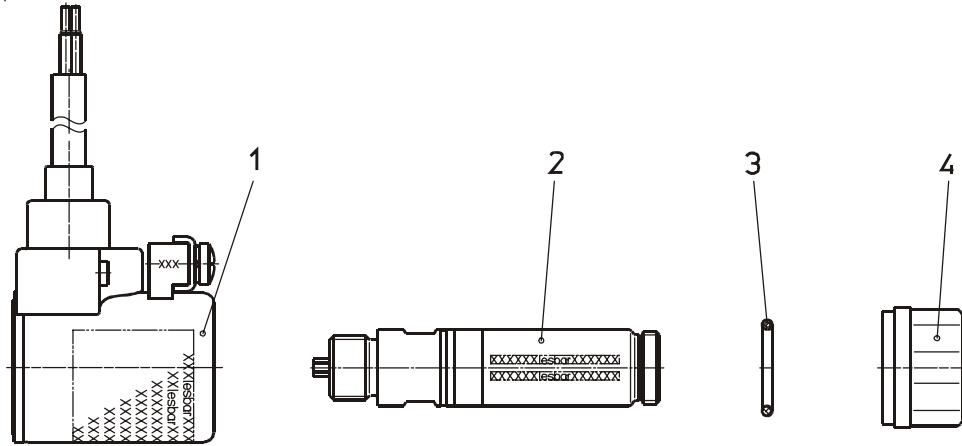

Fig. 6: Proportional Solenoid G RC E 037 AMX A01

## Single Components



consecutive number	quantity	description
1	1	magnetic body f. 24 VDC
2	1	tube
3	1	round sealing ring 19 x 2.5 70 Sh-A NBR
4	1	fixing nut

## Fixing Nut

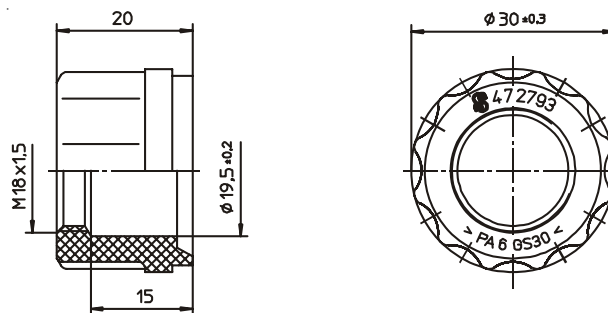

**Fig. 7:** Fixing Nut 472793  
 suitable socket wrench SW26 (bihex DIN 3124)  
 O-Ring to be used: 19 x 2.5 70 Shore A  
 closing torque 5 <sup>+1</sup> Nm



## Type code

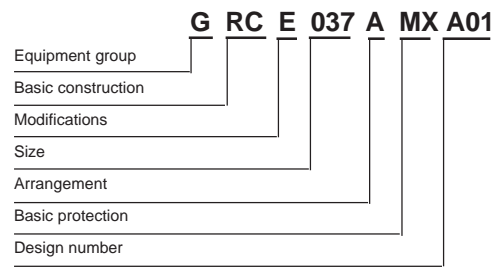

## Order Example

Type	G RC E 037 AMX A01
Voltage	== 24 V DC
Operating mode	S1 (100% ED)

## Specials

Special designs and modifications are available on request for which full application conditions should be specified in accordance with our  Technical Explanations.